



The Embroiderer

Newsletter of The Embroiderers' Guild of Western Australia Inc.
Guild House 565 Canning Highway Alfred Cove WA 6154
PO Box 85 Applecross WA 6953
Telephone: (08) 9330 3065 ABN 88 207 941 050

Website embroiderersguildwa.org.au
Email admin@embroiderersguildwa.org.au
Facebook www.facebook.com/embroiderersguildofWA

Patron: The Honourable Kim Beazley AC
Governor of Western Australia

ISSN 2207-7138

No. 316

February / March 2019

Happy 50th Anniversary

Embroiderers' Guild of WA

1969 - 2019



✧
Celebrating 50
years of
embroidery,
friendship, sharing
and community

✧
Join us for a
year-long party

- ✧ Exquisitely Gifted Exhibition – May 22nd - 26th
✧ Anniversary Celebration Lunch – July 12th
✧ Threads of Gold Convention – September 20th - 22nd

President's Report

Dear Members,

Happy New Year to you and your families. I hope you have had a relaxing January as 2019 promises to be an exciting and busy year of celebrations for the Guild. I also hope that your New Year resolutions included making some time each day/week to continue to develop your embroidery skills and knowledge. The Guild is here to assist you in these endeavours. Perhaps you might do a class from the workshop programme, borrow a book (or two or three) from the Library, purchase a book from our new book sales area or organise a local workshop with one of our expert local tutors. Please let me know if there are other ways the Guild might assist you in this journey. You can be sure that the Management Committee will actively consider each and every idea.

In December last year we had two pieces of good news that augured well for 2019. The first was that the Honourable Kim Beazley AC, Governor of Western Australia, has agreed to be our Patron. This continues a long tradition of patronage of the Guild by the State's Governor, and we are delighted and honoured by Mr Beazley's demonstration of support in this way.

The second was that the new shelves for the Library were installed. Not only do they look good but they provide additional shelving space, as one set goes along part of the wall adjacent to the existing shelves. Once the Library stocktake is completed the Library will reopen for business in late January. Thanks to Dellys, Kaye and the team of Library volunteers who undertake this task each year.

As the position of City Vice-President was still vacant in December, Jenny Stephenson (refreshed after a six-week break travelling to Melbourne) agreed to fill the position on a strictly time limited basis. I am of course delighted with this, as many city members know Jenny and she brings enormous knowledge and interest to the Management Committee. I am, however disappointed that no other member of the Guild has stepped up to fill this vital role. The functions of the City Vice-President are mainly around liaising between the City Groups and the Management Committee to ensure good two-way communication. While the City Vice-President may be called upon to Chair Management Committee meetings in my absence, the Committee is not an unruly one and chairing it is not difficult! There is now no expectation that the City VP will become the next President, so if that was putting you off please now take time to talk to myself or Jenny about the position.

The Management Committee met in January to make sure that we were equipped to meet the challenges of this, our 50th year. An enormous amount of work goes into each event at local and state (Guild) level. Fortunately, much of this background work has been done in 2018 so we hope that we are all set to enjoy the various events. If you are looking to hold a local event to celebrate the Guild's 50th Anniversary, please let us know so we can share it with other members.

That enough for now, so happy stitching.

Prudence

From The Editor

Welcome to your first newsletter for 2019. I hope everyone had a wonderful and relaxing Christmas. Mine was (unusually) very quiet and relaxed, involving champagne and prawns and a lot of chilling out.

In this issue we have an update about all the 50th Anniversary celebrations, as well as group news and information about various other exhibitions and Guild events coming up this year. I have received a lot of contributions to get you enthused for a 'stitchy' 2019 – thank you everyone.

I would like to also thank everyone for their feedback about my first issue – very much appreciated!

Michelle

Diary Dates

Workshop Registration Closing Dates	No.3 (Foundations 1)	9 February 2019
	No. 4 (Exploring Stitches, Threads & Textures)	20 February 2019
	No.5 (A Crewel Plan)	22 March 2019
	No.6 (Turkman Cap)	26 April 2019
	No.7/8 (Couturier Chatelaine/Mamluck Purse)	27 April 2019
	No.9/10/11 (Hanazume/Iris Circle/Japanese/Chinese continuance)	8 May 2019

Workshop booking form can be found at:

[Workshop Enrolment & Cancellation Policy](#)

or <https://bit.ly/2SVV4wg>

Deadline for the Apr/May issue of The Embroiderer	15 March 2019	Exquisitely Gifted Exhibition	22-26 May 2019
Certificate Group Meeting Days 2019	3 February 2019	Threads of Gold Celebratory Lunch	Friday 12 July 2019 (Karrinyup Country Club)
	28 April 2019		
	9 June 2019	Threads of Gold Convention	20-22 Sep 2019
	4 August 2019		
13 October 2019	AGM	19 October 2019	

Back Issues of The Embroiderer

Past issues of The Embroiderer are available in electronic or hard copy format. The price of a hard copy is \$5, plus postage if applicable. Enquiries to the Editor theembroiderer@westnet.com.au

GUILD ANNOUNCEMENTS

Welcome to the new member who joined between 13 Nov 2018 and 29 Jan 2019.
Happy stitching to you.

Lace

Janet Tombleson

East Victoria Park

Embroiderers' Guild Gift Vouchers

What better gift for a fellow embroiderer than a gift voucher to spend on books, a workshop etc.
Available from the office, in multiples of \$5.

GUILD HOUSE – NORMAL HOURS OF OPENING

The office is manned on Tuesdays and Thursdays 9.00am to 2.00pm. Messages can be left on the answering machine at any time. Access to library and other facilities is as follows:

Monday	10.00am – 3.30pm	2nd Thursday	9.00am – 3.00pm
Tuesday	9.00am – 2.45pm	2nd and 4th Friday	9.00am – 12noon
Wednesday	Workshops	2nd Saturday of month	9.30am – 3.00pm
Thursday	9.00am – 2.00pm	4th Saturday of month	10.00am – 3.00pm

Parking is limited behind Guild House (please do not park in the access lanes); spaces are available at nearby shops.



Left: Workshop No.6 'Turkman Cap' with Alison Snepp

6-7 June 2019

The theme for this year's Royal Perth Show is:

CITRUS



50TH ANNIVERSARY CELEBRATIONS ROUNDUP

Exquisitely Gifted Exhibition

The countdown has begun, and the organising committee is in a flurry of anticipation to see your exhibition entries. Entries must be completed before 25th March. Group Leaders will collect your items and arrange to deliver them to Guild House during the week of 25th – 29th March. Marilyn Bolton, Country Vice-President will liaise with country groups about getting members' entries to Guild House.

Lone Members, please deliver your entries to Guild House between 9.30am and 2.00pm, from 25th – 29th March. A committee member will be there to receive them.

Your committee has only 1½ days in which to set up approximately 300 items in the Convention Centre – a very short amount of time! Please have mercy on those who transport, unpack, arrange and re-pack exhibits, and help us to create a magnificent display by doing the following:

- ☺ Ensure pictures are ready to hang, with hinged rings and cord on the back approximately 1/3rd down from the top.
- ☺ Ensure soft hangings have a rod sleeve and please supply the rod.
- ☺ Supply any props needed to display your entry.
- ☺ Ensure all exhibits are correctly labelled in a discreet place and that all props, packaging and bags are labelled.
- ☺ Ensure your entry is appropriately packed and protected in a padded bag if possible (see page 7 for instructions on making a padded bag)

More detailed information has been emailed to Group Leaders. An information sheet and entry form for Lone Members will be attached to the February Group Letter.

From Labour to Leisure Display

The Collection Group's contribution to the Exhibition will be a display of items from the Historic Textile Collection that depict the changing place of embroidery in the lives of women, from the 1800s when embroidery was a way for women and girls to earn a living, through to the middle of the 20th Century when embroidery became mainly a leisure activity and embroidered items were used to decorate the home.

This will be a very interesting display that tells a story about some very special items in the Collection. It will complement members' exhibits and inform the public about the treasures in our Textile Collection.

50th Celebration Lunch

The lunch is on Friday 12th July at the Lake Karrinyup Country Club. Cost will be \$60 per head. We promise to amaze with prizes, surprises and unexpected happenings. Why not organise a table of group members or your special Guild friends so that you can enjoy, reminisce and share a wonderful time together.

This is going to be a golden gala occasion and there will be prizes for the best-dressed golden girl or boy, and a prize for the best gold hat. So, get those fingers working to make wonderful and original creations to show what you can do. Remember - too much bling is never enough. We will let you know when we start taking bookings for this fabulous celebratory event.

Threads of Gold Convention

The celebrations continue with the Convention from 20th – 22nd September. Come for one, two or three days. There are an incredible number and variety of workshops and lectures each day for you to choose from. Grab the opportunity to see, hear and learn, or take the time to relax with friends or make new ones in an embroidery-filled environment. You can see the Convention brochure on our website at www.embroiderersguildwa.org.au under the 50th Anniversary tab, or email prudence.ford15@westnet.com.au for more information.

Fundraising

You have been wonderful, with over \$17,000 raised so far. Thank you so much. Can we make it to \$20,000? Bet we can!

Speaking of funds, I know of a group that intends to use their surplus funds to help their members get to 50th Anniversary events. Does your group have money in the bank? Might that be a good way to use it and support the 50th celebrations at the same time? Country groups, please remember that there are funds available to assist Country members (including Country Lone members) to get to the 50th anniversary events. Please contact Marilyn Bolton for more information at gumnutsgh@westnet.com.au.

We need your help !

The 50th Celebrations Committee would like donations of: **old or disused scissors (any size, shape or type), thimbles, cotton reels, embroidery tools** etc. We would also appreciate any **gold fabric, lace, braid, threads** etc. We can't tell you what we intend to do with this stuff – it's a surprise – but you won't get it back (or maybe you will, but it won't look anything like what you gave us). There's a riddle for you! You will have to come to the Celebration Lunch to find the answer.

Please place these items in the labelled box in Guild House as soon as possible.

Glen Hall
For the 50th Anniversary Committee

PADDED BAGS FOR SAFE TRANSPORT OF EXHIBITION PIECES

Padded bags are a great way to protect your exhibition pieces during transportation. The padded bag saves you having to wrap your piece in old towels or pillow slips which those having to unpack your items hate because we have to keep track of them and store them for the duration of the exhibition. A padded bag saves all that extra work for your hardworking organising committee.

Here is a simple guide to making a padded bag.

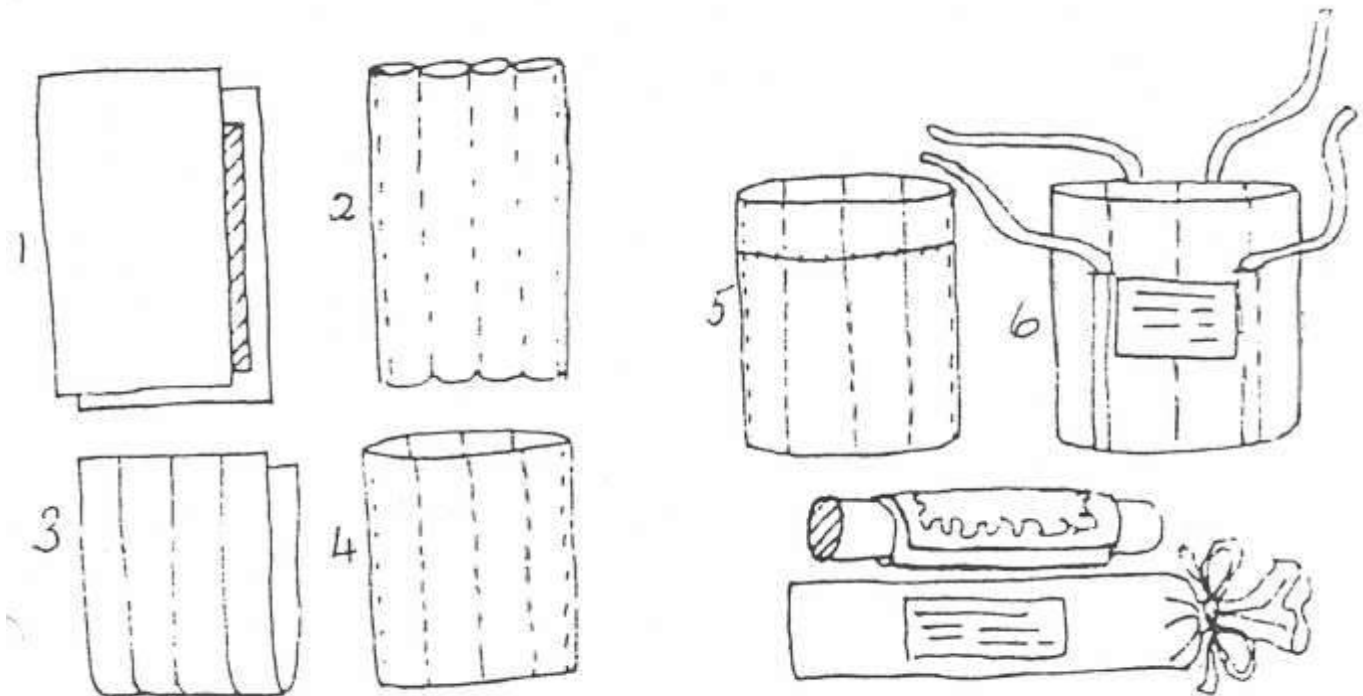

1. Cut two pieces of fabric the required size and a piece of wadding just a little smaller.
2. Place wadding between layers of fabric, pin in place then machine-stitch several lines straight through to hold the layers together.
3. Now fold in half and stitch a narrow seam on the right side.
4. Turn right side inside and stitch seam again (French seam).
5. Turn a hem and stitch round.
6. Turn right side out and add tapes for tying.
7. Attach your label to the outside of the bag.

Commercially quilted fabric can also be used, in which case start at Step 3.

If you are using a cylinder, wrap the embroidered piece round the outside of the cylinder and then put in your bag and secure.

Our thanks to the willing team of helpers who pack The Embroiderer for postage each issue.

BILLETS FOR OUR 50th ANNIVERSARY CELEBRATIONS

To assist the Guild's country members to participate in as many of the celebrations planned for this year as possible, we are proposing to establish a central billet register. This is aimed at linking members wanting billets with those able to offer accommodation for one or more events. Most of us have experienced being billeted or billeting someone else, and when there is a shared interest such as embroidery these arrangements are fun. In many cases friendships develop which are often sustained over years or decades.

To get this register started, if you are able to billet someone please let us know which event(s) ie the Exhibition, 50th Celebration Lunch, Convention or Post-Convention workshops, and the dates for which you can provide accommodation. If you can accommodate more than one person please include that along with your name, email address and contact number.

Similarly, if you are a country member and would like to be billeted please give us the same information (the event, the nights you would like, your name, email address and contact number).

In providing us with this information you will be agreeing that it will be used to match up those offering accommodation and those requiring this by the event and the dates. You will also be agreeing that your contact details (name, email address and telephone number) can be shared with the host member. It is expected that discussions regarding the exact arrangements will take place directly between the two parties.

We are hoping that this process will make it easier for country embroiderers to find like-minded people in Perth with whom they can stay when attending events and workshops.

To ask any questions or to add your name and details to the register please contact:

Prudence Ford: Email prudence.ford15@westnet.com.au
Tel 0417 982 137

or Marilyn Bolton: Email gumnutsgh@westnet.com.au
Tel 0427 525 590



Above: Embroiderers' Guild of WA Logo – worked in goldwork by Kaye Menzies for the Exquisitely Gifted Exhibition



Above: 'All mushrooms are edible – some only once' - stumpwork by Tania Cohen

LIBRARY STOCKTAKE

The library stocktake held in January is now completed.

Unfortunately the following items were missing:

COWAN, Sally	Left Handed Stitchery	A/COW
NICHOLS, Marion	Encyclopaedia of Embroidery Stitches	A/NIC
Magazines-	Down Under Textiles No. 14 & 17	
	Inspirations No. 77	
	Craft Arts No. 87	

Please check to see if you have any of these items and return them to the library desk.

Many thanks to Irene McBride and Joan Eddy for their help.

Dellys Rodgers & Kaye Menzies

EGWA MANAGEMENT COMMITTEE MEETINGS

At the January meeting of the Management Committee, we decided to move most of our meetings to the third Saturday of the month from 9.00am to 11.00am. The change in day is to enable members who are in paid employment to participate in Management Committee meetings as much as those who have fewer paid commitments. Some meetings are still scheduled for a Friday due to other important Guild activities scheduled for the relevant Saturday. Members of the Guild are welcome to come and observe Management Committee meetings if they wish.

Hence, the times and dates for 2019 are as follows:

- 18th January
- 16th February (Saturday, 9.00am to 11.00am)
- 15th March (Friday, 9.00am to 11.00am as Saturday 16th is Leaders Day)
- 27th April (as 20th April is Easter) (Saturday, 9.00am to 11.00am)
- 18th May (Saturday, 9.00am to 11.00am)
- 22nd June (Saturday, 9.00am to 11.00am)
- 20th July (Saturday, 9.00am to 11.00am)
- 17th August (Saturday, 9.00am to 11.00am)
- 28th September (as the 21st September is the Convention) (Saturday, 9.00am to 11.00am)
- 18th October (Friday 9.00am to 11.00am then set up main hall for the AGM which is the next day)
- 16th November (Saturday, 9.00am to 11.00am)
- 14th December (Saturday, 9.00am to 11.00am, meeting plus Christmas lunch).

Prudence Ford
President

EXPRESSIONS OF INTEREST

to purchase and remove the wood and glass display cabinet from Guild House.

Given the extensive renovations to Guild House over the last three years and the recent replacement and expansion of the Library bookshelves, the Guild Management Committee has decided to review (with a view to improving) the display and storage facilities available in the Rusty Walkley Hall.

As a first step we have decided to call for Expressions of Interest (EOIs) in buying and removing the wood and glass display cabinet. The cabinet has been used at Guild House for many years and is in very good condition. As it no longer meets our requirements, we would like it to have a good new home.

We are therefore calling for expressions of interest, including a monetary offer, to buying it as is. A condition of the purchase is that the buyer removes the cabinet from Guild House at their own expense.

EOIs will close on 28 February 2019 and all EOIs will be considered by the Management Committee.

This is a recent photograph of the Cabinet. If any member is interested in viewing it in person, you can see it at Guild House when the office is staffed (Tuesdays and Thursdays, 9.00am to 2.00pm).

If you have any questions about the EOI process or the cabinet, please contact:

Prudence Ford, President, EGWA

Email prudence.ford15@westnet.com.au
or
Mobile 0417 982 137



*Left: Exquisitely Gifted -
'Continuity' by Raye Farcic*

AVALON RETREAT APRIL 2019

Happy New Year everybody!

All the rooms are now booked for Avalon this year, so apologies to anyone who was still thinking about it. You will have to get in quick next year!

The dates are Monday, 8th April to Thursday, 11th April 2019 inclusive.

For those of you who are already booked in it is now time to start thinking about making your final payment. \$325.00 is now due for those sharing, and \$480.00 for those having a single room.

Payment can be made via direct deposit to the Guild or by contacting myself or Pip Reid with your credit card details. Early payments would be appreciated - thanks everyone.

Guild Banking Details: Embroiderers Guild of WA
Commonwealth Bank Booragoon
BSB: 066102
Account No: 00902598
(please remember to include your name/Avalon payment on the transfer)

Further info about payments: Pip Reid (Guild Treasurer) 0406 475 801 reidpip@gmail.com

If you would like any further information about the retreat, please contact me on 9892 3007 or 0427 525 590, or email me at gumnutsgh@westnet.com.au . I would love to hear from you.

Marilyn Bolton
Country Vice President



'WEAR TO?' GROUP'S BIG PLANS FOR 2019

The Guild's 'Wear To?' Group has been running for over 2 years and is now firmly established, with a band of dedicated members committed to extending their embroidery and innovative textile skills to create functional clothing that suits their body shape, personality and sense of style.

Shopping for clothes can be a disheartening experience for many of us as we sort through racks and racks of clothes and discard them for lacking sleeves, wrong colour, awful print, too loose, too clingy, too short, too long etc.

'Wear To?' members are overcoming these problems by designing and making their own unique garments, ensuring they always have something stylish for a special occasion or just for everyday wear. You don't have to be a skilled dressmaker to benefit from this Group. Members share their skills. Some of us have great dressmaking and construction experience, whilst others are proficient in embroidery and design. Between us all we have what we need to achieve our aims, as well as having a sense of fun.

In 2019 the Group is undertaking a series of workshops that will guide us through designing a unique applique to go on a one-of-a-kind dress or jacket. The workshops will deal with design, colour and placement as well as the actual stitching of the design and construction. These skills can also be applied to existing garments. It is very satisfying to be able to revamp that much-loved dress that has been hanging in the wardrobe for 5 years.

By July we will all have something stunning to wear to the Guild's 50th Celebration lunch. Watch us show off!

Why not come and join us? The group meets on the 3rd Saturday of the month at Guild House, from 9.30am to 3.00pm. Group fees are \$50 per year which covers the costs of workshops, refreshments and amenity fees.

If you interested in joining the group contact Helen Jones, Group Leader, on 0418 927 511 or at helenowenjones@aapt.net.au.

Glen Hall



Hand painted and appliqued coat (work in progress) by Helen Jones

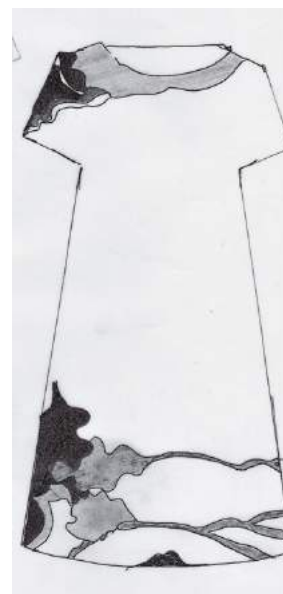

Applique design for a dress by Helen Jones

SUNDAY SAMPLINGS

Over the past four years I have been lucky to attend most of the meetings of the Sunday Samplings Group. This group was run by Raelene Vinciullo (ably assisted by Sherri and Sue Wilding) and met once a month at Guild House.

Raelene took us through all the groups of stitches, gently guiding those new to the stitches whilst at the same time challenging those who thought they knew them by offering variations! The class notes and instructions were always clear and understandable with superb stitch diagrams. Raelene also shared with us her considerable knowledge of different techniques, fabrics, threads and equipment.

Those of you who have enrolled (or are going to enrol) for the Foundations 1 course are in for a real treat!

Thank you Raelene for challenging me, guiding me and encouraging me over the past four years. I feel I am a better embroiderer for having been to these meetings.

Molly Clark



Raelene and Sherri



Majestic Merino

Classes: see website for details. Workshops include Embroidery Basics & Advanced, Stumpwork & Design.

* **Prudence Mapstone** in May 2019 for Freeform Knit & Crochet.

Supplies: For all your embroidery needs: www.majesticmerino.com

Threads: DMC; Gumnuts; House of Embroidery; Cottage Garden Threads; (and YLI & Gloriana by pre order).

Fabrics: Linens; Quilting Cottons; Whisper Weft; Aida; Homespun

Frames & Hoops; Needles (including Tulip); Scissors & More; Knitting Yarns & Patchwork Fabrics

**Phone 98401172; Email gail@majesticmerino.com
Mail Order, visit Nornalup or free delivery to Guild House monthly.**



Bookings are open for the 50th Anniversary Convention next September. You can see the Convention brochure on the Guild website at www.embroiderersguildwa.org.au under the 50th Anniversary tab, or click on the links below:

[Threads of Gold Brochure](#)

[Online Booking Facility](#)

Booking form for printing out if you wish to send it in the mail:

[Printable Booking Form](#)

Threads of Gold - Commemorative Tea Towels

The 50th Anniversary Committee is proud to present these beautiful commemorative tea towels for purchase. They will make lovely gifts for your friends and family. The design is digitally printed on excellent quality 50% linen/50% cotton.

All funds raised go towards supporting 50th Anniversary events.

Tea towels can be purchased for **\$20.00** each, at Guild events or from Guild House.

For further information, please contact

Marilyn Bolton gumnutsgh@westnet.com.au or

Prudence Ford prudence.ford15@westnet.com.au

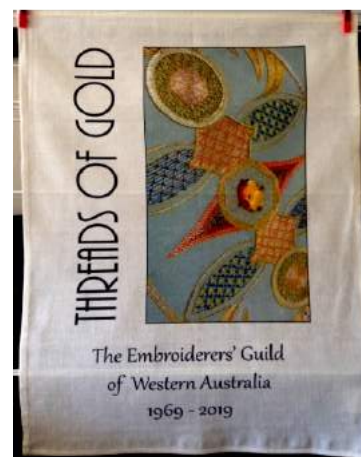

Goldwork design worked by Audrey Spittler



Round is the first solo Show for textile artist and long-time Guild member Gail Hawes. It will be held at City Arts Space, Northbridge Piazza (cnr James and Lake Street, Northbridge) from Saturday 23rd February until 3rd March 2019.

ROUND A CONTEMPORARY TEXTILE EXHIBITION
BY GAIL HAWES

23 FEBRUARY – 3 MARCH 2019 | 10AM – 6PM DAILY

Further information about Gail's exhibition can be found at:

<https://www.soulfulstitches.com.au/round-exhibition/>

GROUP NEWS

Denmark & South Coast Groups Gathering

On 20th November 2018 our group invited members from the Albany group to join us for a catch-up and show and tell of the embroidery everyone had made during the year.

Our Country Vice President arranged to have a selection of items from the Guild's archive brought down, so we had the opportunity of looking at some very different and beautiful embroidery – there were lots of awed comments.

The embroiderers from Albany brought with them their Albany Show entries, with once again an amazing display of their prize-winning pieces.

Not to be outdone, our Denmark girls showed their Albany Show entries too - well done to all participants. Overall a total of 19 prizes were won: 7 firsts, 6 seconds and 6 thirds, as well as a Best Embroidery Exhibit in Show and a Highly Commended.

It was a really happy day of renewing our friendships, admiring each other's embroidery and enjoying lunch together, and it was agreed we should do it again soon!

Leonie Loveday Denmark Embroiderers



Some of the winners from the Denmark Embroidery Group-

Left at back: Leonie Loveday, Julie Nayda, Louise Hoskins, Deb Dickie, Lyn Schupp

Front from left: Julia Churchill, Margaret Cocks

(winners absent from photo: Marilyn Bolton, Gail Guthrie)

Members of the **Lace Group** held a festive Christmas lunch, with a fabulous table centerpiece.



Table decorations courtesy of Clare and Jill

GROUP NEWS

Members of the **Albany South Coast** Embroidery Group enjoyed their Christmas party on the 11th December 2018. It was held at a new venue at Boronia Gardens Community Hall – the home of Doris and Nell. 22 of us were accommodated very nicely in an L-shaped table beautifully decorated with green and red boxes made by Marguerite, and filled with cake and bon-bons by Pat.

The food was excellent (we all brought a plate to share) and Nell made a thirst-quenching lemon punch. We had all made a gift out of red material we had been given earlier in the year. Each gift was totally different and quite lovely to receive. These Christmas parcels were passed around to a “left and right story” read out by Beth. Once completed, we then had to own up to who had made which article!

We have a perpetual annual spot prize (a spot is placed randomly under one chair), which this year was won by Thelma – underwear; a thong and size 10 mini bra!

Another prize was a “white elephant bag” – designed to take what you like from it and replace with something for next year. This was won by Pat.

We all enjoyed a happy and wonderful day, and would like to wish everyone a Happy New Year.

Marguerite Gwynn
Albany South Coast Group



Applecross Group

How pleasing it is to finish an item and have it ready for a little joy at Christmas time. With Janine Wells' generous assistance – she provided materials cut to size, kits, enthusiasm and guidance to achieve the completion of these Temari balls – all of the ladies in the Applecross group were able to share in the glory. Thanks Janine, thanks Brenda and thanks to those members that helped the other members. One project started and finished in a timely manner!



The Embroiderers' Guild NSW's **Festival of Samplers** will run from 14th - 24th June 2019.

In addition to an exhibition and workshops, the festival includes a one-day Sampler Symposium at Gallery 76 Queen Street - a full day of talks on various aspects of the historical practice and significance of sampler making. Price includes morning tea, lunch and a drinks reception held at the gallery in the evening.

Places for the Symposium are strictly limited. The early bird price of \$80 ends on 1st Feb at which point the standard ticket price of \$100 applies – however, EGWA members are eligible for a discounted price of \$90 after 1st Feb.



Further info and bookings: www.embroiderersguildnsw.org.au

[Facebook Event Page](#)

<https://www.trybooking.com/ZQIY>

<https://www.trybooking.com/450448>



*Left: Exquisitely Gifted -
'Medieval City 1' - canvaswork by Ann-Marie Anderson-
Mayes*

LIBRARY NEWS

New Books

BLOMKAMP Hazel & VAN NIEKERK Di

Freestyle Embroidered Mandalas

Ca/BLO

From simple monochromatic line designs to colourful and flamboyant bead and thread combinations, the 27 embroidered mandalas will inspire everyone from the beginner to the most experienced stitcher.

RHODES Shelley Sketchbook Explorations for Mixed Media and Textile Artists Sc/RHO

Renowned textile artist Shelley Rhodes offers a wealth of advice on creating and working with sketchbooks in mixed media, from gathering inspiration to displaying finished books. Beautifully illustrated, this book contains inspiring examples from leading textile and mixed media artists.

RAKESTRAW, Sarah & HINDE, Susan

Glorious Goldwork

Ch/RAK

Sarah and Susan are a mother and daughter team and are goldwork experts. They show you how to identify the goldwork wires and threads and the techniques used to apply them, through clear text and step-by-step instructions.

VICTORIA & ALBERT MUSEUM

Embroidery A Maker's Guide

Bb/EMB

A modern maker's guide to embroidery traditions around the world, this book is guaranteed to expand your stitching horizons. It contains 15 beautiful step-by-step projects to suit all levels. Each one takes its cue from a different tradition, including English goldwork, Indian beetle-wing embellishment, bargello and blackwork, as well as contemporary machine embroidery.

Dellys Rodgers & Kaye Menzies

	<p>Craft & Quilt Fair 2019</p> <p>22 – 26 May</p> <p>Perth Convention & Exhibition Centre</p>
--	--



Left: Workshop No.5 'A Crewel Plan' with Rita Petters – 3-4 May 2019

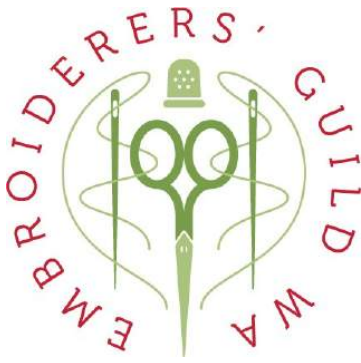

Workshop & Guild Calendar 2019

Feb 2019	2nd – 3rd	No.1 Elizabethan Tree Panel with Maree Talbot	\$ 140
	3rd 6th - 7th	Certificate Group No.2 Elizabethan Needlework Accessories with Maree Talbot	\$ 140
March 2019	2nd - 3 rd 16 th	No.3 Foundations 1 with Raelene Vinciullo	\$ 80
	30 th – 31 st 31 st	Leaders Day No.3 Foundations 1 with Raelene Vinciullo (cont.) Deadline for entries to the Exquisitely Gifted Exhibition	
April 2019	3rd	No.4 Exploring Stitches, Threads & Textures with Jenny Stephenson	\$ 50
	12 th – 13 th 28 th tbc	Kalamunda Show Certificate Group National Heritage Month Talk : Guild House	
May 2019	3rd – 4th 22nd - 26th	No.5 A Crewel Plan with Rita Petters 50th Anniversary Exhibition at Craft & Quilt Fair	\$ 100
June 2019	6 th – 7 th	No.6 Turkman Cap with Alison Snepp	\$ 140
	8 th - 9 th	No.7 Couturier Chatelaine with Alison Snepp	\$ 105
	9 th – 10 th	No.8 Mamluck Purse with Alison Snepp	\$ 105
	9 th 19 th – 23 rd	Certificate Group No.9 Hanazume/Wild Iris with Margaret Lee	\$ 70 per day
	20 th - 23 rd 22 nd – 23 rd	No.10 Japanese Bead Embroidery Petite Fleur Purse or Box top or Continuance with Margaret Lee No.11 Chinese Embroidery Wild Iris or Continuance with Margaret Lee	\$ 70 per day \$ 70 per day
July 2019	12 th	50th Anniversary Celebration Lunch Karrinyup Country Club	
August 2019	4 th	Certificate Group	
Sept 2019	20 th - 22 nd 23 rd – 29 th	50th Anniversary Convention Post-Convention Workshops	See brochure for details/costs https://bit.ly/2D53ixj
	28 th – 5 th Oct	Perth Royal Show (Theme: <i>Citrus</i>)	
October 2019	13 th	Certificate Group	
	19 th	AGM	

Please advise the Editor of any other embroidery-related dates you would like included.

MANAGEMENT COMMITTEE MEMBERS 2018-2019

President	Prudence Ford	0417 982 137	prudence.ford15@westnet.com.au
City Vice-President	Jenny Stephenson	0419 042 957	jensteph@iinet.net.au
Country Vice-President	Marilyn Bolton	9892 3007	gumnutsg@westnet.com.au
Secretary	Leanne Barker	0412 888 627	leanne.barker@iinet.net.au
Treasurer	Pip Reid	0406 475 801	reidpip@gmail.com
Editor	Michelle Long	0421 273 865	theembroiderer@westnet.com.au
Public Relations Officer	Jenny Quartermaine	0400 682 078	jennique@optusnet.com.au
House Coordinator	Joan Sibenaler	0417 095 307	fjsibenaler1@bigpond.com
Member	Bev Wasylkewycz	0422 659 903	bevwas@hotmail.com
Member	Sandy Mack	0439 189 777	sandram@westnet.com.au
Member	Elizabeth Mortley	0405 838 033	elizabethmortley134@gmail.com
Member	Helen Jones	9330 6967	helenowenjones@aapt.net.au
Membership Secretary	Kathryn Kenny	9437 5321	kathryn.kenny@bigpond.com
Past President	Jenny Stephenson	0419 042 957	jensteph@iinet.net.au

OTHER OFFICERS

Administration Officer	Wendy Myles	9330 3065	admin@embroiderersguildwa.org.au
Book Sales	Colleen Donaldson	9418 3094	donno@iinet.net.au
Librarian	Dellys Rogers	9330 1452	brodgers1@bigpond.com
Textile Collection	Valerie Cavill	9386 2196	jandvcavill@bigpond.com
Chairperson Awards Comm	Maryvonne Hollister	9364 7730	mholister4@gmail.com
New Member Liaison Officer	Susan Wilding	9574 1409	mokine@activ8.net.au
House Supplies & Hospitality	Joan Sibenaler	0417 095 307	fjsibenaler1@bigpond.com
Guild House Displays	Margaret Lofthouse	9450 1338	admin@embroiderersguildwa.org.au
Website & Social Media Coordinator	Jenny Quartermaine	0400 682 078	jennique@optusnet.com.au

JUNIOR GROUPS

JETS Coordinator	Margaret Lofthouse	9450 1338	admin@embroiderersguildwa.org.au
------------------	--------------------	-----------	--

EDUCATION SUB-COMMITTEE MEMBERS

Coordinator	Jill Merker	0413 333 668	jill@merker.com.au
Local Tutors	Isobel Laurance	0417 778 515	ilaurance@gmail.com
Interstate/Overseas Tutors	Jill Merker	0413 333 668	jill@merker.com.au
Secretary	Christine Ross	0417 994 849	sk_cl_ross@yahoo.com
Personal Development Coordinator	Raelene Vinciullo	0419 352 148	raelenevin@westnet.com.au
Workshop Registrar	Elizabeth Robson	0411 961 806	lizzie@wn.com.au
Workshop Coordinator	Julia Shugg	9339 8756	shuggp@bigpond.net.au
Hostess Coordinator	Rita Petters	9342 8955	pettersrita@gmail.com
Support/PR	Elizabeth Mortley	0405 838 033	elizabethmortley134@gmail.com